

Small, light and high speed and torque 5-phase stepper motor driver

■ Features

- Bipolar constant pentagon drive method
- Includes Auto Current Down and self-diagnosis function
- Low speed rotation and high accuracy controlling with microstep-driving (Except for MD5-ND14)
 [Max. resolution - 250 division / In case of 5-phase stepper motor of which basic step angle is 0.72°, it enables to control up to 0.00288° per pulse and it requires 125,000 pulses per rotation.]
- Photocoupler input insulation method to minimize the effects from external noise



⚠ Please read "Caution for your safety" in operation manual before using.



(Except for MD5-HF14-AO, MD5-HD14, ND14)

■ Ordering information

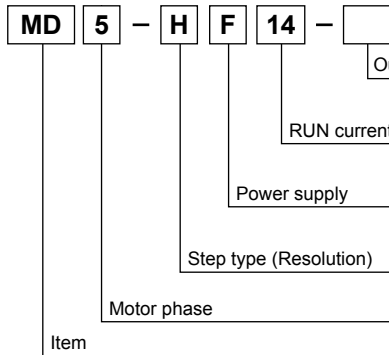

Output	No mark	Zero point excitation output ^{※1}
	AO	Alarm output
RUN current	14	1.4A/Phase
	28	2.8A/Phase
Power supply	D	20-35VDC
	F	100-220VAC
Step type (Resolution)	H	Micro step(250divisions)
	N	Normal Step
Motor phase	5	5-Phase
Item	MD	Motor Driver

※KR-55MC can be replaced with MD5-HD14.
 ※KR-5MC can be replaced with MD5-ND14.
 ※MD5-MF14 can be replaced with MD5-HF14.
 ※KR-505G can be replaced with MD5-HF28.

※1: Except MD5-ND14

■ Specifications

Model	MD5-HD14	MD5-HF14	MD5-HF14-AO	MD5-HF28	MD5-ND14
Power supply	20-35VDC 3A ^{※1}	100-220VAC 50/60Hz			20-35VDC 3A
RUN current	0.4 to 1.4A / Phase			1.0 to 2.8A / Phase	0.5 to 1.5A / Phase
RUN method	Bipolar constant pentagon drive				
Basic step angle	0.72° / Phase				
Resolution	1, 2, 4, 5, 8, 10, 16, 20, 25, 40, 50, 80, 100, 125, 200, 250 division (0.72° to 0.00288° / Phase)				1, 2 division (0.72°, 0.36° / Phase)
Input pulse width	Min. 0.5μs			0.1μs	Min. 10μs
Pulse Duty	50%				
Rising/Falling time	Max. 120ns			Max. 1μs	Max. 120ns
Max. input pulse frequency ^{※2}	1MHz			500kHz	50kHz
Input voltage level	High : 4-8VDC, Low : 0-0.5VDC				
Input resistance	270Ω(CW, CCW) 390Ω(HOLD OFF, DIVISION SELECTION)		270Ω(CW, CCW) 390Ω(HOLD OFF)		270Ω(CW, CCW) 390Ω(HOLD OFF, DIVISION SELECTION) 390Ω
Environment	Ambient temperature	0 to 40°C, storage: -20 to 60°C		0 to 50°C, storage: -10 to 60°C	
	Ambient humidity	35 to 85%RH, storage: -10 to 90%RH			35 to 85%RH, storage: -10 to 90%RH
Approval	CE	CE c UL US	CE	CE c UL US	CE
Unit weight	Approx. 220g	Approx. 660g	Approx. 650g	Approx. 1kg	Approx. 120g

※1: When using over 30VDC, it should be mounted at ventilated place due to increasing heat.

※2: Max. pull-out frequency and max. slewing frequency are variable depending on resolution, or load.

※Environment resistance is rated at no freezing of condensation.

(A)	Photo electric sensor
(B)	Fiber optic sensor
(C)	Door/Area sensor
(D)	Proximity sensor
(E)	Pressure sensor
(F)	Rotary encoder
(G)	Connector/Socket
(H)	Temp. controller
(I)	SSR/ Power controller
(J)	Counter
(K)	Timer
(L)	Panel meter
(M)	Tacho/ Speed/ Pulse meter
(N)	Display unit
(O)	Sensor controller
(P)	Switching mode power supply
(Q)	Stepper motor & Driver&Controller
(R)	Graphic/ Logic panel
(S)	Field network device
(T)	Software
(U)	Other

MD5 Series

5-Phase micro stepper motor driver [MD5-HD14]

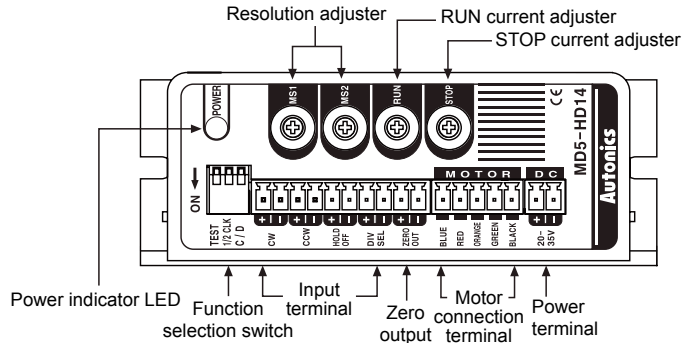

◎ Function selection switch



NO	Name	Function	Switch position	
			ON	OFF
1	TEST	Self-diagnosis	Rotate in 30rpm	Not using
2	1/2 CLK	Pulse input method	1 Pulse input	2 Pulse input
3	C/D	Auto current down	Not using	Using

● TEST

- ※ Self-diagnosis function is to test motors and drivers.
- ※ Motors rotate with 30 rpm in full-step. Motor rotation speed is subject to change depending on resolution setting.
- ※ Rotation speed = 30 rpm / resolution
- ※ The motor will rotate in CCW direction when in 1-pulse input mode and in CW direction when in 2-pulse input mode.
- Note) Make sure that TEST switch is set to OFF before supplying the power.
It may cause injury or danger if TEST switch is set to ON when power is supplied.

● 1/2 CLK

- ※ 1/2 CLK switch is to select pulse input mode.
- ※ 1-pulse input mode : CW → operation command pulse input, CCW → rotation direction pulse input
([H] : CW rotation, [L] : CCW rotation)
- ※ 2 Puls input mode : CW → CW direction rotation pulse input, CCW → CCW direction rotation pulse input

● C/D (Auto current down)

- ※ This function is reducing current automatically according to STOP current setting value in order to suppress generated heat when motor is stop.
- ※ It activates when there is no pulse input of motor operation for over 200ms.

◎ RUN current setting

S/W No	0	1	2	3	4	5	6	7	8	9	A	B	C	D	E	F
Current (A/Phase)	0.4	0.5	0.57	0.63	0.71	0.77	0.84	0.9	0.96	1.02	1.09	1.15	1.22	1.22	1.33	1.4

- ※ RUN current is a phase current provided to 5-phase stepper motor.
- ※ Be sure to set RUN current at the rated current or below.
- ※ Adjust the RUN current in case severe heat generation occurs. Be sure that torque decreasing may occur when adjusting the current.
- Note) Be sure to adjust RUN current while motor is running.

◎ STOP current setting

Switch No.	0	1	2	3	4	5	6	7	8	9	A	B	C	D	E	F
%	27	31	36	40	45	50	54	58	62	66	70	74	78	82	86	90

- ※ STOP current is a phase current provided to 5-phase stepper motor at standstill.
- ※ It will be activated when C/D (Auto current down) is set to ON. By setting STOP current, it is possible to suppress the heat generation at motor standstill.
- ※ STOP current setting value is the ratio of RUN current setting value (%).
- Ex) In case RUN current setting value is set to 1.4A and STOP current setting value is set to 50%, auto current down current is set to 0.7A.
- ※ STOP current setting value may have some deviation depending on resistance impedance of motor.
- ※ Auto current down function will be activated when HOLD OFF signal is [L]. When HOLD OFF signal is [H], the function is not activated since the current provided to each phase is cut off.
- Note) Be sure to adjust STOP current while motor is at standstill.

Stepper Motor Driver(1.4A/phase, DC Power)

◎ Zero point excitation output signal (ZERO OUT)

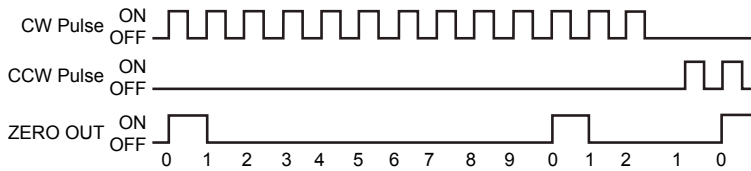

※The signal is output to indicate when the motor excitation status is in the initial stage. Used to check the rotation position of motor's axis.

※In case of full step, the signal is output every 7.2°. (50 times / rotation).

Ex) Full step (0.72°/Step) : Signal is output every 10 pulses

20 divisions (0.036°/Step) : Signal is output every 200 pulses.

◎ HOLD OFF function

※When HOLD OFF input signal is [H], motor excitation is released.

When HOLD OFF input signal is [L], motor excitation is in a normal status.

※A function used to rotate motor's axis using external force or used for manual positioning.

※HOLD OFF Input signal [H] and [L] represent photocoupler ON/OFF in a circuit.

※Please do not use for stopping motor.

◎ Setting microstep(Microstep : Resolution)

Switch No.	0	1	2	3	4	5	6	7	8	9	A	B	C	D	E	F
Resolution	1	2	4	5	8	10	16	20	25	40	50	80	100	125	200	250
Step angle	0.72°	0.36°	0.18°	0.144°	0.09°	0.072°	0.045°	0.036°	0.0288°	0.018°	0.0144°	0.009°	0.0072°	0.00576°	0.0036°	0.00288°

● Resolution setting(Same as MS1, MS2)

※It is set to MS1 when division selection signal is [L], and MS2 when division selection signal is [H].

※Two different micro step can be set using DIVISION SELECTION. Users can select one of them via external input signals.

※Microstep is to make basic step angle of 5-phase motors (0.72°) divided into smaller angle according to setting values.

※The formula for microstep angle is ;

$$\text{Motor revolution angle (5-phase motors)} = \frac{\text{Basic step angle}(0.72^\circ)}{\text{Resolution}}$$

※In case of geared motors, step angle shall be determined by dividing step angle by gear ratio.

EX) $0.72^\circ / 10 (1:10) = 0.072^\circ$

※It may cause step-out if resolution is changed while motor is running.

■ Input-Output diagram

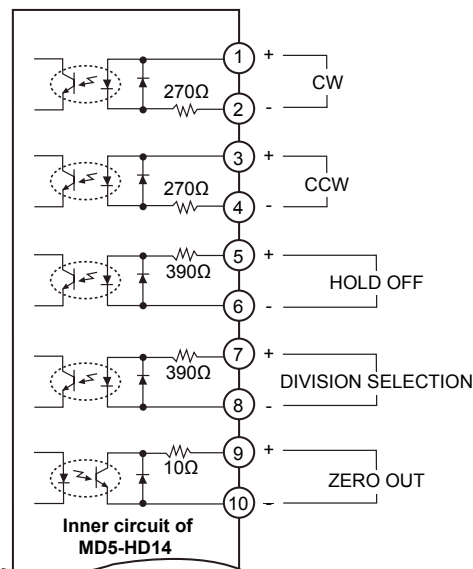

※CW

2-pulse input mode - CW direction rotation pulse input
1-pulse input mode - Operation command pulse input

※CCW

2-pulse input mode - CCW direction rotation pulse input
1-pulse input mode - Rotation direction pulse input
[H] : CW, [L] : CCW

※HOLD OFF

Motor excitation OFF control signal
[H] : Motor excitation OFF

※DIVISION SELECTION

Division selection signal
→ [L] : Operated by MS1 setting resolution.
[H] : Operated by MS2 setting resolution.

※ZERO OUT

Zero point excitation output signal ON for zero point excitation

(A) Photo electric sensor

(B) Fiber optic sensor

(C) Door/Area sensor

(D) Proximity sensor

(E) Pressure sensor

(F) Rotary encoder

(G) Connector/Socket

(H) Temp. controller

(I) SSR/Power controller

(J) Counter

(K) Timer

(L) Panel meter

(M) Tacho/Speed/ Pulse meter

(N) Display unit

(O) Sensor controller

(P) Switching mode power supply

(Q) Stepper motor & Driver&Controller

(R) Graphic/Logic panel

(S) Field network device

(T) Software

(U) Other

MD5 Series

Connections

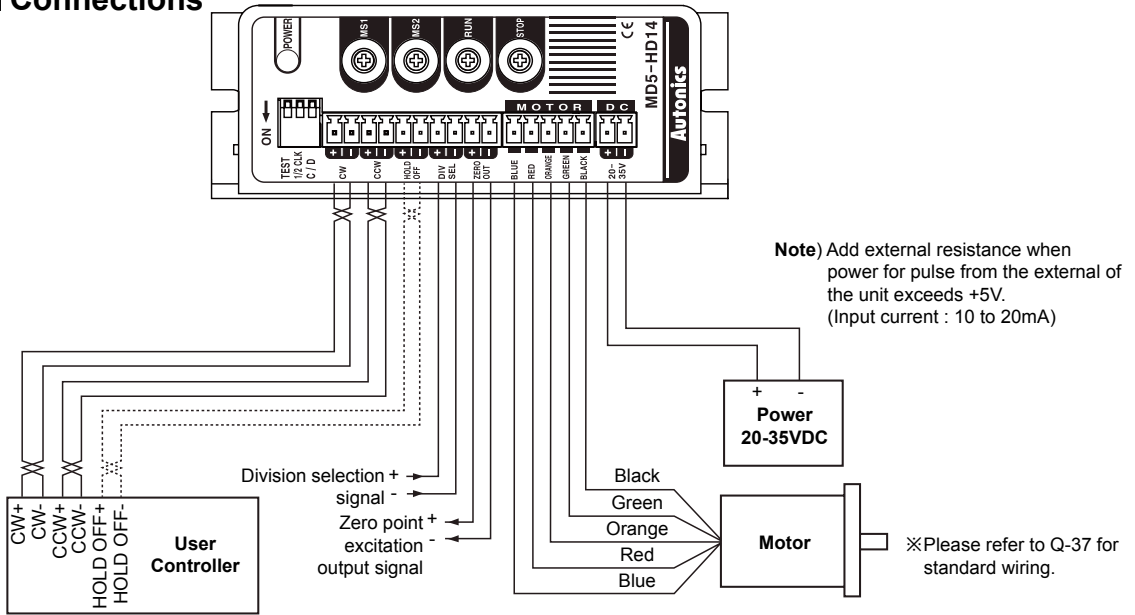

Dimensions

(unit: mm)

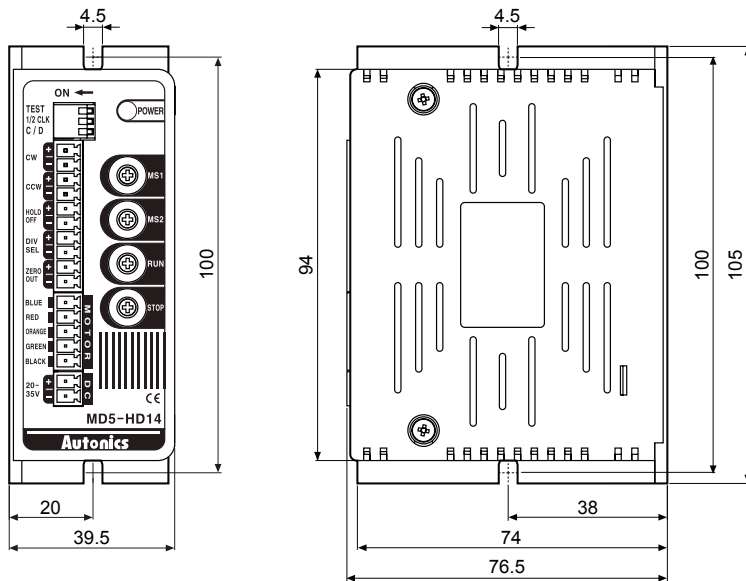

Stepper Motor Driver(1.4A/phase, AC Power)

5-Phase Micro stepper motor driver [MD5-HF14]

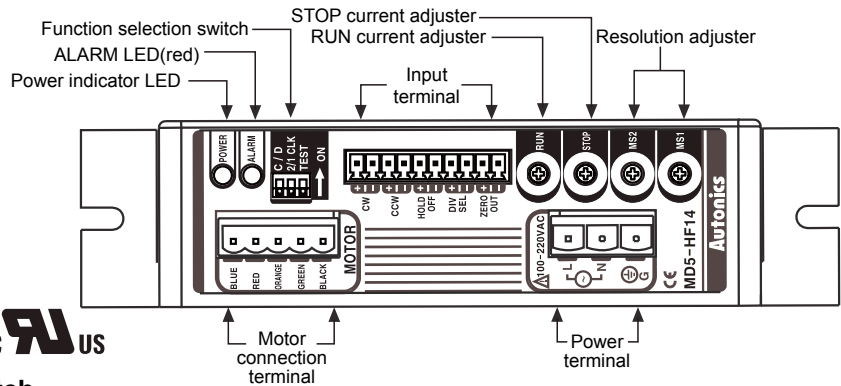

◎ Function selection switch



NO	Name	Function	Switch position	
			ON	OFF
1	TEST	Self-diagnosis	Rotate in 250Hz	—
2	2/1 CLK	Pulse input method	1 Pulse input	2 Pulse input
3	C/D	Auto current down	Not using	Using

●TEST

- ※Self-diagnosis function is to test motors and drivers.
 - ※Motors rotate with 250Hz in full-step. Motor rotation speed is subject to change depending on resolution setting.
 - ※Rotation speed = 30 rpm / resolution
 - ※The motor will rotate in CCW direction when in 1-pulse input mode and in CW direction when in 2-pulse input mode.
- Note) Make sure that TEST switch is set to OFF before supplying the power.
It may cause injury or danger if TEST switch is set to ON when power is supplied.

●2/1 CLK

- ※1/2 CLK switch is to select pulse input mode.
- ※1-pulse input mode : CW → operation command pulse input, CCW → rotation direction pulse input
([H]: CW rotation, [L]: CCW rotation)
- ※2-Puls input mode : CW → CW direction rotation pulse input, CCW → CCW direction rotation pulse input

●C/D (Auto current down)

- ※This function is reducing current automatically according to STOP current setting value in order to suppress generated heat when motor is stop.
- ※It activates when there is no pulse input of motor operation for over 200ms.

Switch No.	0	1	2	3	4	5	6	7	8	9	A	B	C	D	E	F
Current (A/Phase)	0.4	0.5	0.57	0.63	0.71	0.77	0.84	0.9	0.96	1.02	1.09	1.15	1.22	1.27	1.33	1.4

- ※RUN current is a phase current provided to 5-phase stepper motor.
 - ※Be sure to set RUN current at the rated current or below.
 - ※Adjust the RUN current in case severe heat generation occurs. Be sure that torque decreasing may occur when adjusting the current.
- Note) Be sure to adjust RUN current while motor is running.

◎ STOP current setting

Switch No.	0	1	2	3	4	5	6	7	8	9	A	B	C	D	E	F
%	27	31	36	40	45	50	54	58	62	66	70	74	78	82	86	90

- ※STOP current is a phase current provided to 5-phase stepper motor at standstill.
 - ※It will be activated when C/D (Auto current down) is set to ON. By setting STOP current, it is possible to suppress the heat generation at motor standstill.
 - ※STOP current setting value is the ratio of RUN current setting value (%).
- Ex) In case RUN current setting value is set to 1.4A and STOP current setting value is set to 50%, auto current down current is set to 0.7A.
- ※STOP current setting value may have some deviation depending on resistance impedance of motor.
 - ※Auto current down function will be activated when HOLD OFF signal is [L]. When HOLD OFF signal is [H], the function is not activated since the current provided to each phase is cut off.
- Note) Be sure to adjust STOP current while motor is at standstill.

(A)	Photo electric sensor
(B)	Fiber optic sensor
(C)	Door/Area sensor
(D)	Proximity sensor
(E)	Pressure sensor
(F)	Rotary encoder
(G)	Connector/ Socket
(H)	Temp. controller
(I)	SSR/ Power controller
(J)	Counter
(K)	Timer
(L)	Panel meter
(M)	Tacho/ Speed/ Pulse meter
(N)	Display unit
(O)	Sensor controller
(P)	Switching mode power supply
(Q)	Stepper motor & Driver & Controller
(R)	Graphic/ Logic panel
(S)	Field network device
(T)	Software
(U)	Other

MD5 Series

◎ Zero point excitation output signal (ZERO OUT)

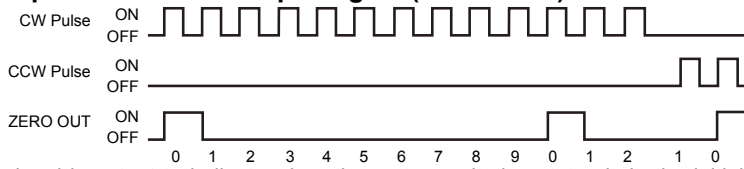

※The signal is output to indicate when the motor excitation status is in the initial stage. / Used to check the rotation position of motor's axis

※In case of full step, the signal is output every 7.2°. (50 times / rotation)

EX) Full step (0.72°/Step): Signal is output every 10 pulses.

20 divisions (0.036°/Step): Signal is output every 200 pulses.

◎ HOLD OFF function

※When HOLD OFF input signal is [H], motor excitation is released.

When HOLD OFF input signal is [L], motor excitation is in a normal status.

※A function used to rotate motor's axis using external force or used for manual positioning.

※HOLD OFF Input signal [H] and [L] represent photocoupler ON/OFF in a circuit.

※Please do not use for stopping motor.

◎ Setting microstep(Microstep : Resolution)

Switch No.	0	1	2	3	4	5	6	7	8	9	A	B	C	D	E	F
Resolution	1	2	4	5	8	10	16	20	25	40	50	80	100	125	200	250
Step angle	0.72°	0.36°	0.18°	0.144°	0.09°	0.072°	0.045°	0.036°	0.0288°	0.018°	0.0144°	0.009°	0.0072°	0.00576°	0.0036°	0.00288°

● Resolution setting(Same as MS1, MS2)

※It is set to MS1 when division selection signal is [L], and MS2 when division selection signal is [H].

※Two different micro step can be set using DIVISION SELECTION. Users can select one of them via external input signals.

※Microstep is to make basic step angle of 5-phase motors (0.72°) divided into smaller angle according to setting values.

※The formula for microstep angle is ;

$$\text{Motor revolution angle (5-phase motors)} = \frac{\text{Basic step angle}(0.72^\circ)}{\text{Resolution}}$$

※In case of geared motors, step angle shall be determined by dividing step angle by gear ratio.

EX) $0.72^\circ / 10 (1:10) = 0.072^\circ$

※It may cause step-out if resolution is changed while motor is running.

◎ ALARM Function

※Over heat: When the temperature in driver BASE is over 80°C, Alarm LED will be ON and motor will stop with holding the torque. Remove the Over Heat Alarm causing factors and reset the power in order to reset alarm function.

※Overcurrent: When overcurrent is applied to the motor due to driver damage or errors, Alarm LED will be flickering.

In case of overcurrent, the motor will be HOLD OFF. Cut off the power and remove overcurrent-causing factors in order to resume normal operation.

■ Input-Output diagram

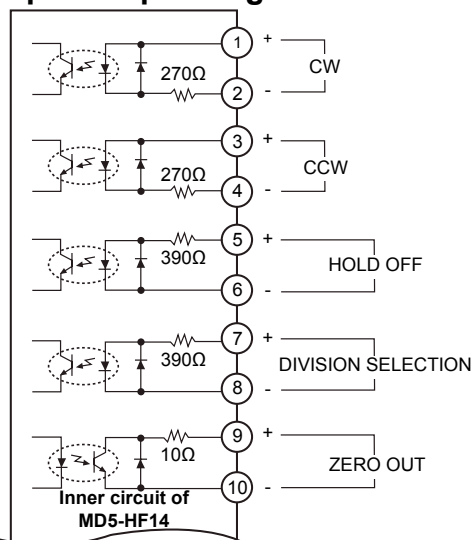

※CW

2-pulse input mode - CW direction rotation pulse input

1-pulse input mode - Operation command pulse input

※CCW

2-pulse input mode - CCW direction rotation pulse input

1-pulse input mode - rotation direction pulse input

[H] : CW, [L] : CCW

※HOLD OFF

Motor excitation OFF control signal

[H] : Motor excitation OFF

※DIVISION SELECTION

Division selection signal

→ [L] : Operated by MS1 setting resolution.

[H] : Operated by MS2 setting resolution.

※ZERO OUT

Zero point excitation output signal ON for zero point excitation

Stepper Motor Driver(1.4A/phase, AC Power)

■ Connections

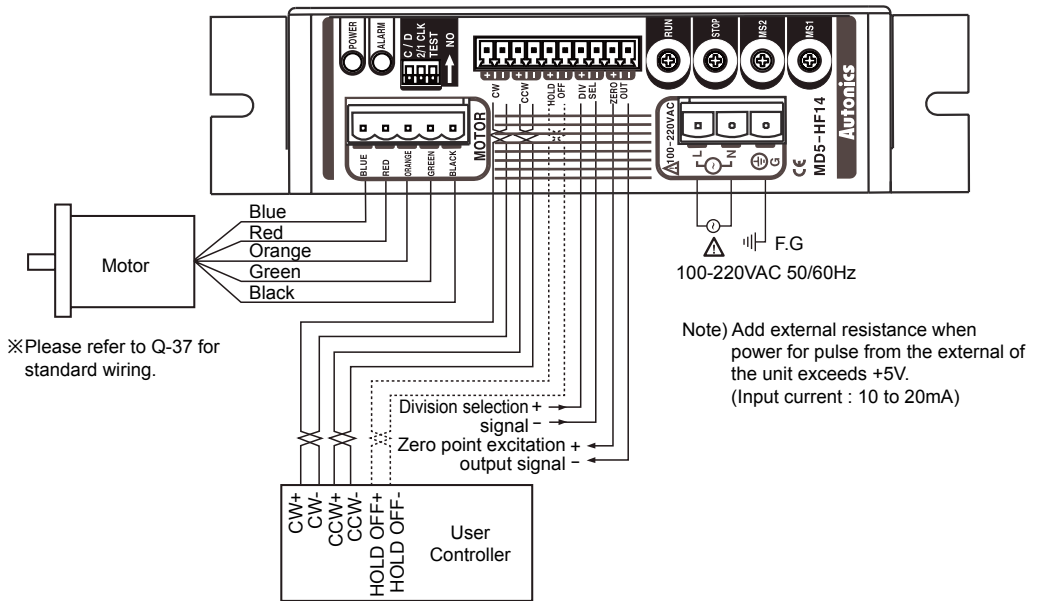

■ Dimensions

(unit: mm)

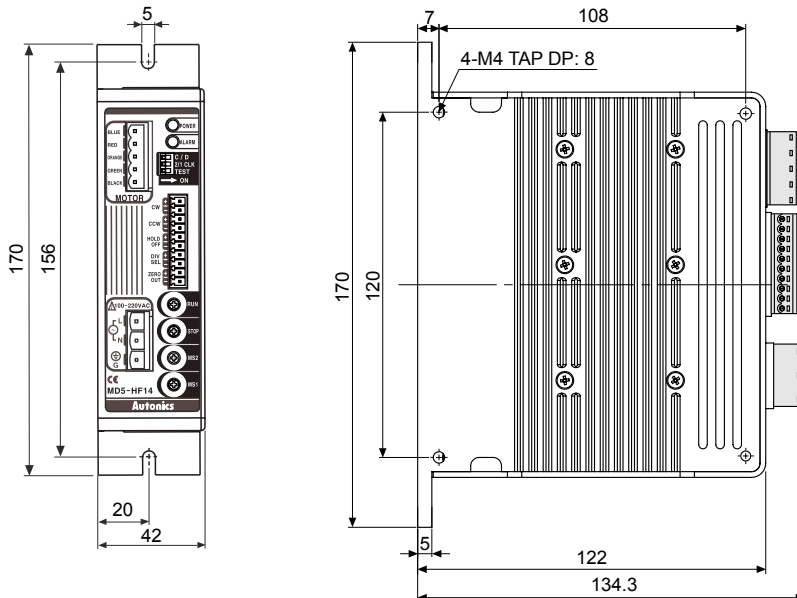

(A)	Photo electric sensor
(B)	Fiber optic sensor
(C)	Door/Area sensor
(D)	Proximity sensor
(E)	Pressure sensor
(F)	Rotary encoder
(G)	Connector/Socket
(H)	Temp. controller
(I)	SSR/ Power controller
(J)	Counter
(K)	Timer
(L)	Panel meter
(M)	Tacho/ Speed/ Pulse meter
(N)	Display unit
(O)	Sensor controller
(P)	Switching mode power supply
(Q)	Stepper motor & Driver&Controller
(R)	Graphic/ Logic panel
(S)	Field network device
(T)	Software
(U)	Other

MD5 Series

5-Phase Micro stepper motor driver [MD5-HF14-AO]

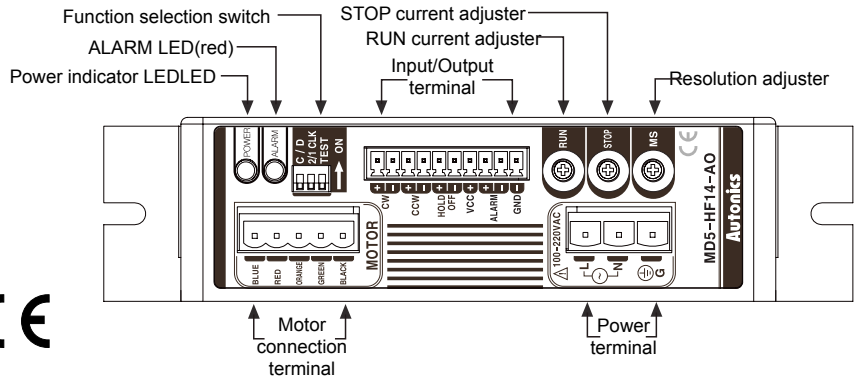

Ⓞ Function selection switch



NO	Name	Function	Switch position	
			ON	OFF
1	TEST	Self-diagnosis	Rotate in 30rpm	—
2	2/1 CLK	Pulse input method	1 Pulse input	2 Pulse input
3	C/D	Auto current down	Not using	Using

● TEST

※Self-diagnosis function is to test motors and drivers.

※Motors rotate with 30 rpm in full-step. Motor rotation speed is subject to change depending on resolution setting.

※Rotation speed = 30 rpm / resolution

※The motor will rotate in CCW direction when in 1-pulse input mode and in CW direction when in 2-pulse input mode.

Note) Make sure that TEST switch is set to OFF before supplying the power.

It may cause injury or danger if TEST switch is set to ON when power is supplied.

● 2/1 CLK

※1/2 CLK switch is to select pulse input mode.

※1-pulse input mode : CW → operation command pulse input, CCW → rotation direction pulse input

([H]: CW rotation, [L]: CCW rotation)

※2 Pulse input mode : CW → CW direction rotation pulse input, CCW → CCW direction rotation pulse input

● C/D (Auto current down)

※This function is reducing current automatically according to STOP current setting value in order to suppress generated heat when motor is stop.

※It activates when there is no pulse input of motor operation for over 200ms.

Ⓞ RUN current setting



Switch No.	0	1	2	3	4	5	6	7	8	9	A	B	C	D	E	F
Current (A/Phase)	0.4	0.5	0.57	0.63	0.71	0.77	0.84	0.9	0.96	1.02	1.09	1.15	1.22	1.27	1.33	1.4

※RUN current is a phase current provided to 5-phase stepper motor.

※Be sure to set RUN current at the rated current or below.

※Adjust the RUN current in case severe heat generation occurs. Be sure that torque decreasing may occur when adjusting the current.

Note) Be sure to adjust RUN current while motor is running.

Ⓞ STOP current setting



Switch No.	0	1	2	3	4	5	6	7	8	9	A	B	C	D	E	F
%	27	31	36	40	45	50	54	58	62	66	70	74	78	82	86	90

※STOP current is a phase current provided to 5-phase stepper motor at standstill.

※It will be activated when C/D (Auto current down) is set to ON. By setting STOP current, it is possible to suppress the heat generation at motor standstill.

※STOP current setting value is the ratio of RUN current setting value (%).

Ex) In case RUN current setting value is set to 1.4A and STOP current setting value is set to 50%, auto current down current is set to 0.7A.

※STOP current setting value may have some deviation depending on resistance impedance of motor.

※Auto current down function will be activated when HOLD OFF signal is [L]. When HOLD OFF signal is [H], the function is not activated since the current provided to each phase is cut off.

Note) Be sure to adjust STOP current while motor is at standstill.

Stepper Motor Driver(1.4A/phase, AC Power, Alarm output)

⊙ HOLD OFF function

※When HOLD OFF input signal is [H], motor excitation is released.

When HOLD OFF input signal is [L], motor excitation is in a normal status.

※A function used to rotate motor's axis using external force or used for manual positioning.

※HOLD OFF Input signal [H] and [L] represent photocoupler ON/OFF in a circuit.

※Please do not use for stopping motor.

⊙ Setting microstep(Microstep : Resolution)

Switch No.	0	1	2	3	4	5	6	7	8	9	A	B	C	D	E	F
Resolution	1	2	4	5	8	10	16	20	25	40	50	80	100	125	200	250
Step angle	0.72°	0.36°	0.18°	0.144°	0.09°	0.072°	0.045°	0.036°	0.0288°	0.018°	0.0144°	0.009°	0.0072°	0.00576°	0.0036°	0.00288°

● Resolution setting

※Microstep is to make basic step angle of 5-phase motors (0.72°) divided into smaller angle according to setting values.

※The formula for microstep angle is ;

$$\text{Motor revolution angle (5-phase motors)} = \frac{\text{Basic step angle}(0.72^\circ)}{\text{Resolution}}$$

※In case of geared motors, step angle shall be determined by dividing step angle by gear ratio.

EX) $0.72^\circ / 10 (1:10) = 0.072^\circ$

※It may cause step-out if resolution is changed while motor is running.

⊙ ALARM OUTPUT Function

※Overheat : When the temperature of inner driver (Base) is over 80°C, Alarm LED (Red) is turned ON and motor becomes HOLD OFF. Turn OFF the power, remove the causes, and re-supply the power to clear the alarm.

※Overcurrent : When overcurrent is applied to motor due to damage by a fire of stepper motor, broken of inner driver, or occurrence of abnormal error, Alarm LED (Red) flashes and motor becomes HOLD OFF. Turn OFF the power, remove the causes, and re-supply the power to clear the alarm.

■ Input-Output diagram

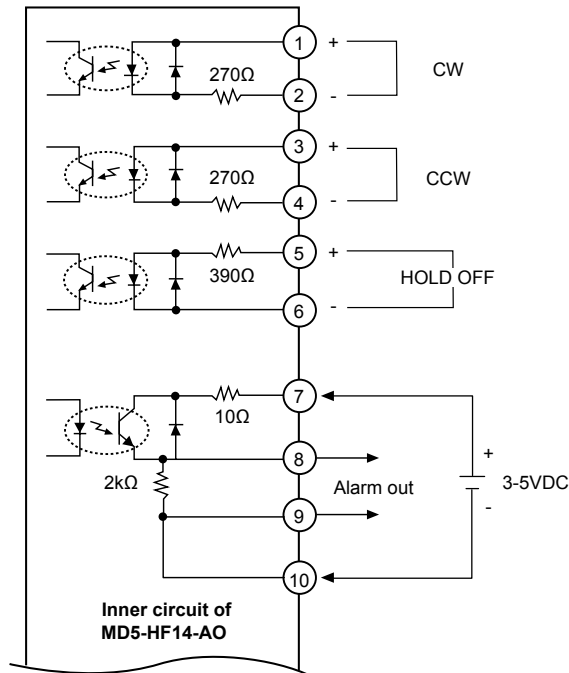

※CW

2-pulse input mode - CW direction rotation pulse

1-pulse input mode - Operation command pulse input

※CCW

2-pulse input mode - CCW direction rotation pulse input

1-pulse input mode - Operation command pulse

[H] : CW, [L] : CCW

※HOLD OFF

Motor excitation OFF control signal

[H] : Motor excitation OFF

※When alarm occurs, it turns HOLD OFF. After cut off the power, remove the causes to operate normally.

※Overheat :



※Over current :



(A) Photo electric sensor

(B) Fiber optic sensor

(C) Door/Area sensor

(D) Proximity sensor

(E) Pressure sensor

(F) Rotary encoder

(G) Connector/Socket

(H) Temp. controller

(I) SSR/Power controller

(J) Counter

(K) Timer

(L) Panel meter

(M) Tacho/Speed/ Pulse meter

(N) Display unit

(O) Sensor controller

(P) Switching mode power supply

(Q) Stepper motor & Driver&Controller

(R) Graphic/Logic panel

(S) Field network device

(T) Software

(U) Other

MD5 Series

■ Connections

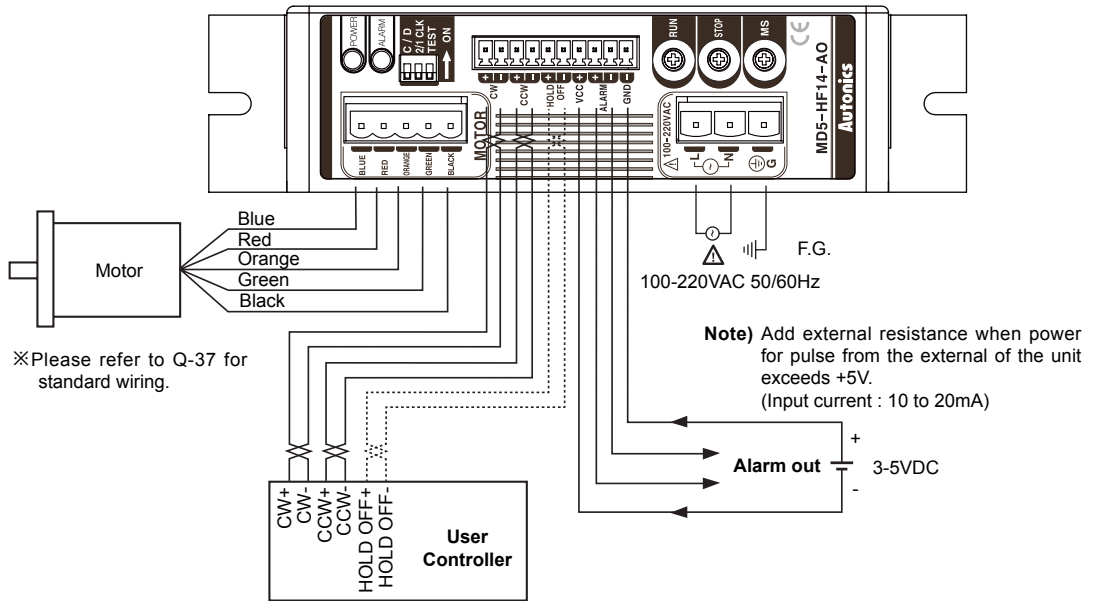

■ Dimensions

(unit: mm)

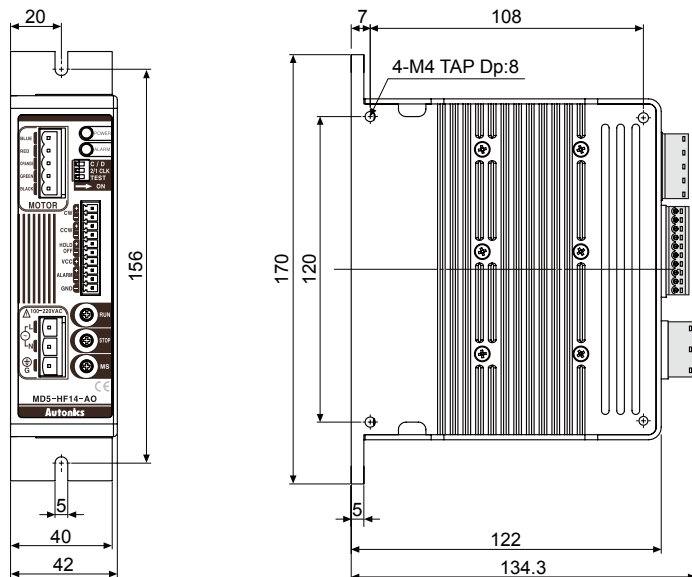

Stepper Motor Driver(2.8A/phase, AC Power)

5-Phase Microstep motor driver [MD5-HF28]

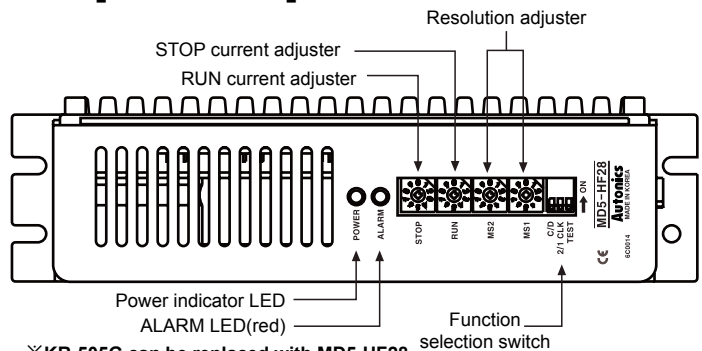

※KR-505G can be replaced with MD5-HF28.
 ※Power supply 100-220VAC and connected socket are upgraded.

Function selection switch



NO	Name	Function	Switch position	
			ON	OFF
1	TEST	Self-diagnosis	Rotate in 250Hz	—
2	2/1 CLK	Pulse input method	1 Pulse input	2 Pulse input
3	C/D	Auto current down	Not using	Using

●TEST

- ※Self-diagnosis function is to test motors and drivers.
 - ※Motors rotate with 250Hz in full-step. Motor rotation speed is subject to change depending on resolution setting.
 - ※Rotation speed = 30 rpm / resolution
 - ※The motor will rotate in CCW direction when in 1-pulse input mode and in CW direction when in 2-pulse input mode.
- Note) Make sure that TEST switch is set to OFF before supplying the power.
 It may cause injury or danger if TEST switch is set to ON when power is supplied.

●2/1 CLK

- ※1/2 CLK switch is to select pulse input mode.
- ※1-pulse input mode : CW → operation command pulse input, CCW → rotation direction pulse input
 ([H]: CW rotation, [L]: CCW rotation)
- ※2-pulse input mode : CW → CW direction rotation pulse input, CCW → CCW direction rotation pulse input

●C/D (Auto current down)

- ※This function is reducing current automatically according to STOP current setting value in order to suppress generated heat when motor is stop
- ※It activates when there is no pulse input of motor operation for over 200ms.

◎ RUN current setting

Switch No.	0	1	2	3	4	5	6	7	8	9	A	B	C	D	E	F
Current (A/Phase)	1.14	1.25	1.36	1.50	1.63	1.74	1.86	1.97	2.10	2.20	2.30	2.40	2.50	2.60	2.78	2.88

- ※RUN current is a phase current provided to 5-phase stepper motor.
- ※Be sure to set RUN current at the rated current or below.
- ※Adjust the RUN current in case severe heat generation occurs. Be sure that torque decreasing may occur when adjusting the current.

Note) Be sure to adjust RUN current while motor is running.

◎ STOP current setting

Switch No.	0	1	2	3	4	5	6	7	8	9	A	B	C	D	E	F
%	27	31	36	40	45	50	54	58	62	66	70	74	78	82	86	90

- ※STOP current is a phase current provided to 5-phase stepper motor at standstill.
 - ※It will be activated when C/D (Auto current down) is set to ON. By setting STOP current, it is possible to suppress the heat generation at motor standstill.
 - ※STOP current setting value is the ratio of RUN current setting value (%).
- Ex) In case RUN current setting value is set to 1.4A and STOP current setting value is set to 50%, auto current down current is set to 0.7A.
- ※STOP current setting value may have some deviation depending on resistance impedance of motor.
 - ※Auto current down function will be activated when HOLD OFF signal is [L]. When HOLD OFF signal is [H], the function is not activated since the current provided to each phase is cut off.
- Note) Be sure to adjust STOP current while motor is at standstill.

- (A) Photo electric sensor
- (B) Fiber optic sensor
- (C) Door/Area sensor
- (D) Proximity sensor
- (E) Pressure sensor
- (F) Rotary encoder
- (G) Connector/Socket
- (H) Temp. controller
- (I) SSR/Power controller
- (J) Counter
- (K) Timer
- (L) Panel meter
- (M) Tacho/Speed/Pulse meter
- (N) Display unit
- (O) Sensor controller
- (P) Switching mode power supply
- (Q) Stepper motor& Driver&Controller
- (R) Graphic/Logic panel
- (S) Field network device
- (T) Software
- (U) Other

MD5 Series

◎ Zero point excitation output signal (ZERO OUT)

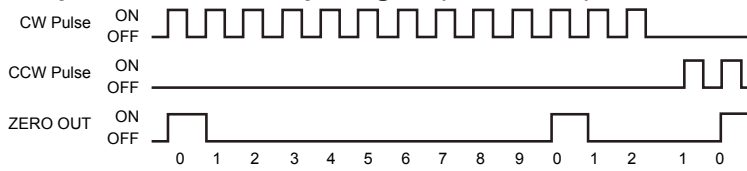

※ The signal is output to indicate when the motor excitation status is in the initial stage. / Used to check the rotation position of motor's axis

※ In case of full step, the signal is output every 7.2°. (50 times / rotation)

EX) Full step (0.72°/Step) : Signal is output every 10 pulses.

20 divisions (0.036°/Step) : Signal is output every 200 pulses.

◎ HOLD OFF function

※ When HOLD OFF input signal is [H], motor excitation is released.

When HOLD OFF input signal is [L], motor excitation is in a normal status.

※ A function used to rotate motor's axis using external force or used for manual positioning.

※ HOLD OFF Input signal [H] and [L] represent photocoupler ON/OFF in a circuit.

※ Please do not use for stopping motor.

◎ Setting microstep(Microstep : Resolution)



Switch No.	0	1	2	3	4	5	6	7	8	9	A	B	C	D	E	F
Resolution	1	2	4	5	8	10	16	20	25	40	50	80	100	125	200	250
Step angle	0.72°	0.36°	0.18°	0.144°	0.09°	0.072°	0.045°	0.036°	0.0288°	0.018°	0.0144°	0.009°	0.0072°	0.00576°	0.0036°	0.00288°

● Resolution setting(Same as MS1, MS2)

※ It is set to MS1 when division selection signal is [L], and MS2 when division selection signal is [H].

※ Two different micro step can be set using DIVISION SELECTION. Users can select one of them via external input signals.

※ Microstep is to make basic step angle of 5-phase motors (0.72°) divided into smaller angle according to setting values.

※ The formula for microstep angle is ;

$$\text{Motor revolution angle (5-phase motors)} = \frac{\text{Basic step angle}(0.72^\circ)}{\text{Resolution}}$$

※ In case of geared motors, step angle shall be determined by dividing step angle by gear ratio.

EX) $0.72^\circ / 10 (1:10) = 0.072^\circ$

※ It may cause step-out if resolution is changed while motor is running.

◎ ALRAM Function

※ Over heat : When the temperature in driver BASE is over 80°C, Alarm LED will be ON and motor will stop with holding the torque. Remove the Over Heat Alarm causing factors and reset the power in order to reset alarm function

※ Overcurrent : When overcurrent is applied to the motor due to driver damage or errors, Alarm LED will be flickering. In case of overcurrent, the motor will be HOLD OFF. Cut off the power and remove overcurrent-causing factors in order to resume normal operation.

■ Input-Output diagram

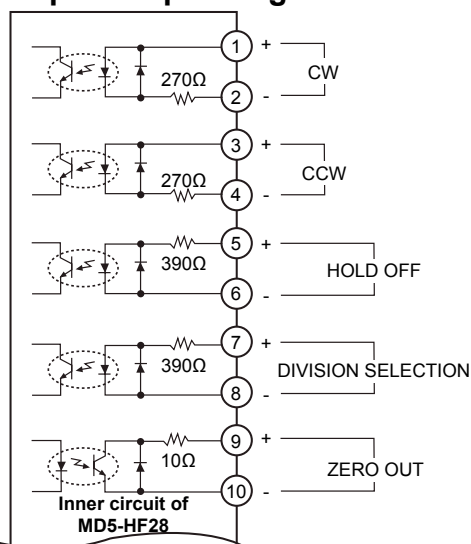

※ CW

2-pulse input mode - CW direction rotation pulse input

1-pulse input mode - Operation command pulse input

※ CCW

2-pulse input mode - CCW direction rotation pulse input

1-pulse input mode - Rotation direction pulse input

[H] : CW, [L] : CCW

※ HOLD OFF

Motor excitation OFF control signal

[H] : Motor excitation OFF

※ DIVISION SELECTION

Division selection signal

→ [L] : Operated by MS1 setting resolution.

[H] : Operated by MS2 setting resolution.

※ ZERO OUT

Zero point excitation output signal ON for zero point excitation

Stepper Motor Driver(2.8A/phase, AC Power)

Connections

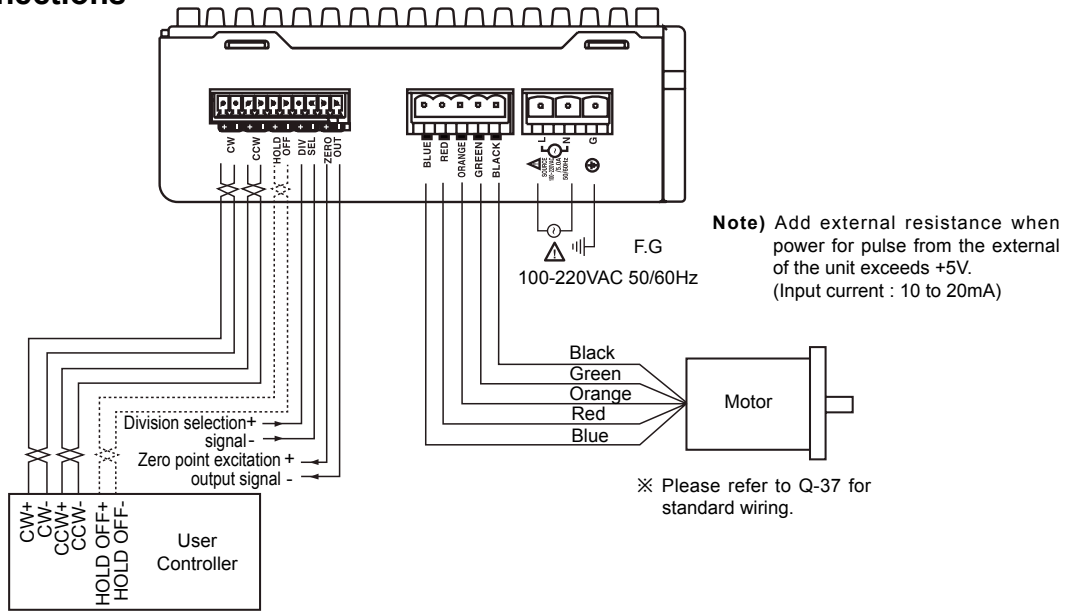

Dimensions

(unit: mm)

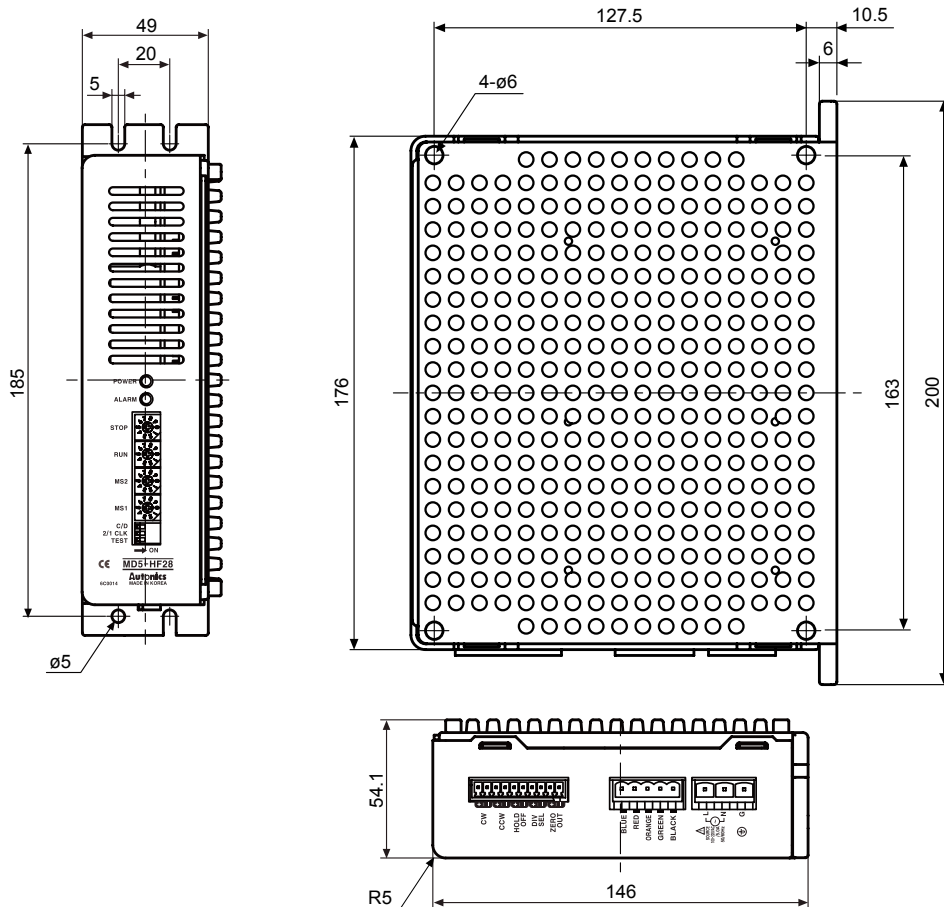

(A)	Photo electric sensor
(B)	Fiber optic sensor
(C)	Door/Area sensor
(D)	Proximity sensor
(E)	Pressure sensor
(F)	Rotary encoder
(G)	Connector/ Socket
(H)	Temp. controller
(I)	SSR/ Power controller
(J)	Counter
(K)	Timer
(L)	Panel meter
(M)	Tacho/ Speed/ Pulse meter
(N)	Display unit
(O)	Sensor controller
(P)	Switching mode power supply
(Q)	Stepper motor & Driver & Controller
(R)	Graphic/ Logic panel
(S)	Field network device
(T)	Software
(U)	Other

MD5 Series

5-Phase stepper motor driver [MD5-ND14]

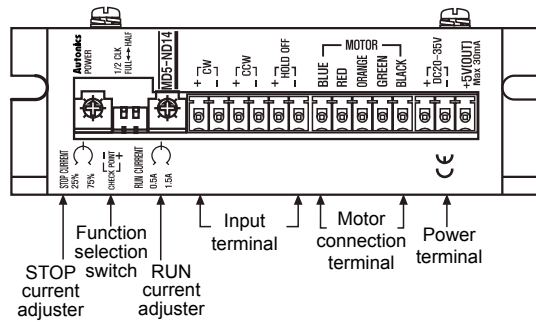

◎ Function selection switch



NO	Name	Function	Switch position	
			ON	OFF
1	1/2 CLK	Pulse input method	1 Pulse input	2 Pulse input
2	FULL ↔ HALF	Resolution Setting	0.72°	0.36°

● 1/2 CLK

※1/2 CLK switch is to select pulse input mode.

※1-pulse input mode : CW → operation command pulse input, CCW → rotation direction pulse input
([H]: CW rotation, [L]: CCW rotation)

※2 Pulse input mode : CW → CW direction rotation pulse input, CCW → CCW direction rotation pulse input

● FULL ↔ HALF

※FULL ↔ HALF switch is to select pulse input mode.

※If changing resolution while the motor is running, it may cause step-out.

◎ RUN current setting



※RUN current is a phase current provided to 5-phase stepper motor.

※Be sure to set RUN current at the rated current or below.

※RUN current setting range: 0.5 to 1.5A

※When changing RUN current, connect CP+ to voltmeter (+) terminal and CP- to voltmeter (-) terminal, then adjust the volume.

※The formula for phase-current setting is ;

$$\text{Setting current(A)} = \frac{\text{CP Input Voltage(V)}}{2}$$

※Adjust the RUN current in case severe heat generation occurs. Be sure that torque decreasing may occur when adjusting the current.

Note) Be sure to adjust RUN current while motor is running.

◎ STOP current setting



25% 75%

※STOP current is a phase current provided to 5-phase stepper motor at standstill.

※A function to reduce the current in order to suppress the heat generation at motor standstill / STOP current setting range : 25 to 75% of RUN current using VR

※In case Run current setting value is set to 1.0A and STOP current setting value is set to 50%, STOP current is set to 0.5A.

※STOP current setting value may have some deviation depending on resistance impedance of motor.

※STOP current function will be activated when HOLD OFF signal is [L]. When HOLD OFF signal is [H], the function is not activated since the current provided to each phase is cut off.

※STOP current function will be activated when no operation command pulse is input within 500ms.

Note) Be sure to adjust STOP current while motor is at standstill.

◎ HOLD OFF function

※When HOLD OFF input signal is [H], motor excitation is released.

When HOLD OFF input signal is [L], motor excitation is in a normal status.

※A function used to rotate motor's axis using external force or used for manual positioning.

※HOLD OFF Input signal [H] and [L] represent photocoupler ON/OFF in a circuit.

※Please do not use for stopping motor.

Stepper Motor Driver(1.5A/phase, AC Power)

Input diagram

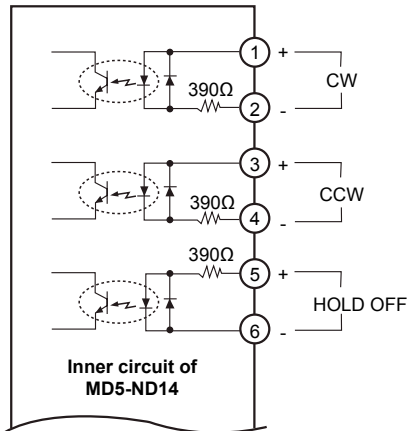

※CW

2 pulse input method(CW direction rotation pulse input)

1 pulse input method(Operating command pulse input)

Note) If the power for driving pulse from external is over than +5V, please connect resistor

※CCW

2 pulse input method(CCW direction rotation pulse input)

1 pulse input method(Rotating direction pulse input)

→ [H] : CW, [L] : CCW

※HOLD OFF

The control signal for hold off of Motor → [H] : Motor Hold OFF

Connections

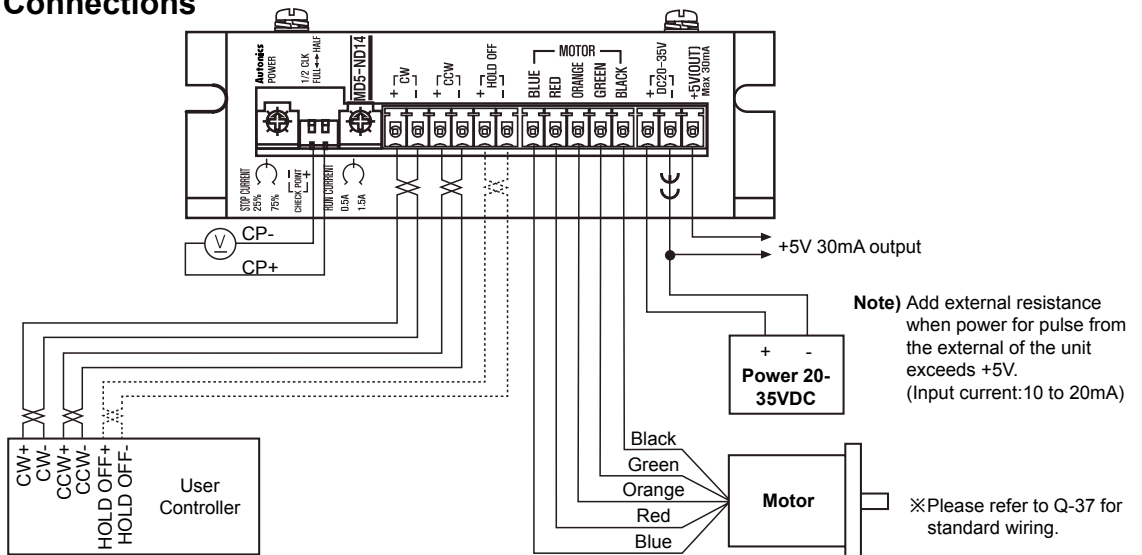

Dimensions

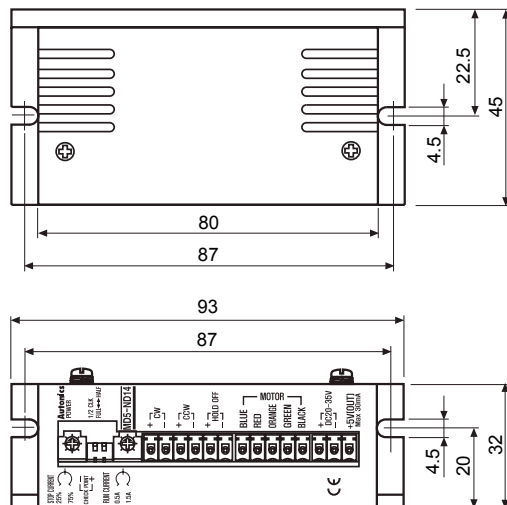

(unit: mm)

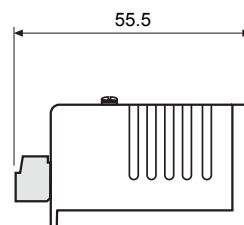

(A)	Photo electric sensor
(B)	Fiber optic sensor
(C)	Door/Area sensor
(D)	Proximity sensor
(E)	Pressure sensor
(F)	Rotary encoder
(G)	Connector/Socket
(H)	Temp. controller
(I)	SSR/ Power controller
(J)	Counter
(K)	Timer
(L)	Panel meter
(M)	Tacho/ Speed/ Pulse meter
(N)	Display unit
(O)	Sensor controller
(P)	Switching mode power supply
(Q)	Stepper motor & Driver & Controller
(R)	Graphic/ Logic panel
(S)	Field network device
(T)	Software
(U)	Other